



"The Standard
of Excellence in
the Industry"

PIPE REPAIR PRODUCTS REPAIR CLAMPS



1213 BADGER STREET • YORKVILLE, ILLINOIS 60560
(630) 553-0840 • (800) 426-4301 • FAX (630) 553-0181
www.cascademfg.com

CASCADE...PIPE REPAIR MADE QUICK & EASY



Wrap clamp around pipe. Bring together using locking washer plate.

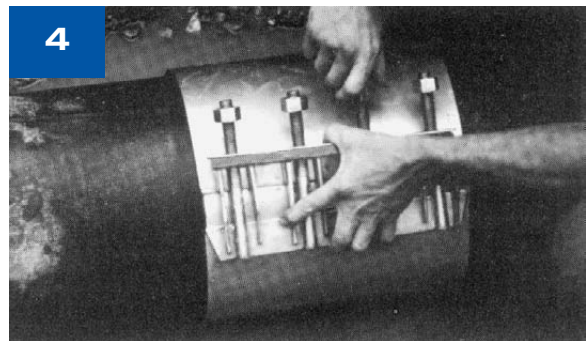
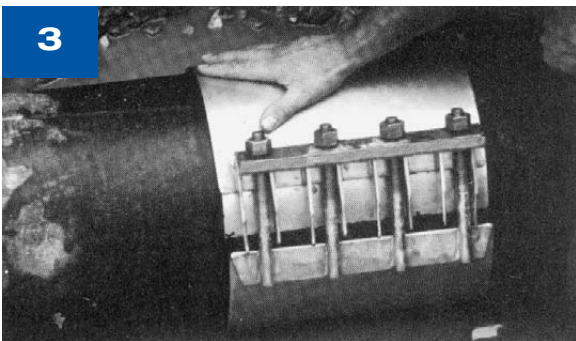

Lock in place. Squeeze the lugs together and spin the nuts down.

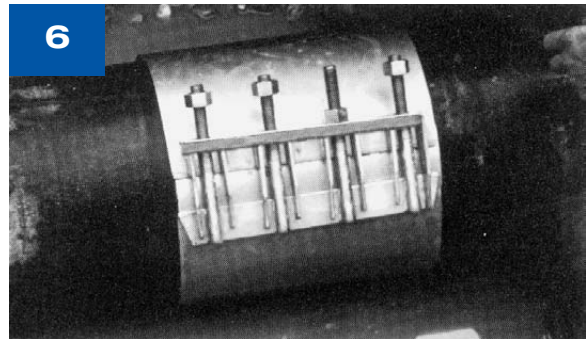

Tighten the nuts evenly working from the outside to the inside with a wrench. Detailed instructions are attached to each clamp.

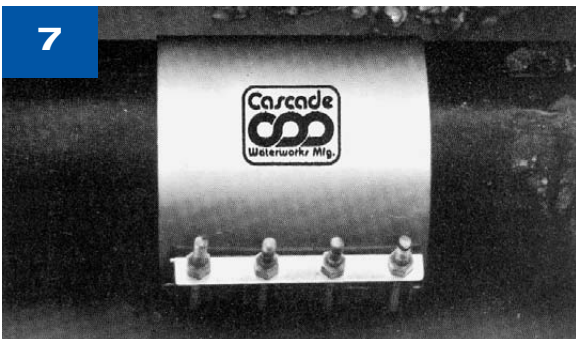

You have just made a permanent repair.

Take a good look at the clamp before you bury it. It's the last time you'll ever see it!



Produced for Logan Diving, Inc. for installation on 48" HDPE with spiraling crack. HDPE line is outfall from a Jacksonville, FL. treatment plant in the Ortega River.

CASCADE designs and produces repair clamps for all kinds of special needs, including very large diameter, varying O.D. sections, high temperatures, concrete joints, and cracked iron pipe Bell joints.

CALL CASCADE WITH YOUR SPECIAL NEEDS

MATERIAL SPECIFICATIONS

CR1

WASHER

PLATE: T-304-SST.
Locks into position for easy tightening of nuts.

FINGER LUGS:

T-304-SST. MIG welded to receiver bar. Leading edge is rounded to permit locking washer plate to slide into position easily.

SHELL: T-304-SST.

STUDS: 18-8 SST, 5/8"-11 rolled NC thread. Studs (7") are MIG welded to bolt bar.

NUTS: 18-8 SST, 5/8"-11 heavy hex, xylan coated

STUD & RECEIVER BARS: T-304-SST. TIG welded to shell.

GASKET: SBR formulated for water service with antioxidant/antiozonant agents to increase shelf life. NITIRILE-EPDM and other compounds available.

ARMOR: T-304-SST.

OUTLET: 18-8-SST. TIG welded to shell.

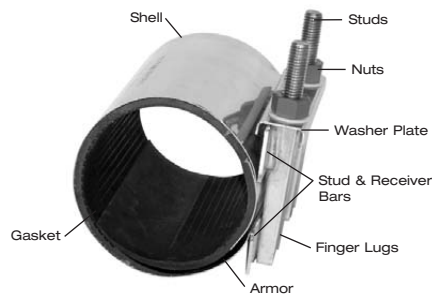

CDR1

LUGS: Ductile Iron ASTM A 536 Grade 65-45-12. Designed for ease of installation.

LUG SHELL & JOINT:

Assured joint design designed for maximum torquing.

SHELL: Stainless Steel T-304.

BOLTS: High strength low alloy steel 5/8" NC AWWA C-111. T-304 SS available.

NUTS: High strength low alloy steel AWWA C-111. T-304 SS available.

GASKET: SBR formulated for water service with antioxidant/antiozonant agents to increase shelf life.

ARMOR: Stainless Steel T-304.

OUTLET: Stainless steel 18-8. TIG welded to shell.

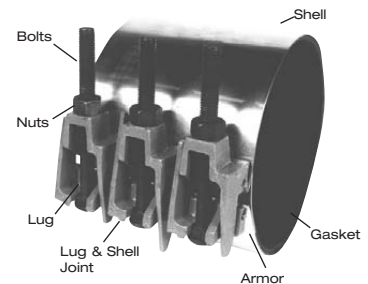

Clamps are also available with T-316 Stainless Steel. Studs and nuts are available in Stainless Steel. Gaskets are available with Nitrile Composition. All welded surfaces are fully passivated in accordance with ASTM A380.



To Order: Determine desired range and length, then select corresponding catalog number.

Note: Other ranges and lengths not listed are available upon request. For higher pressures, clamp length should be equal to or in excess of pipe O.D.

Conductivity Strips available upon request.

Nominal Pipe Size (Inches)	Clamp O.D. Range (Inches)	Catalog Number	Approximate Shipping Weight (lbs.) per length							
			6"	8"	10"	12"	16"	20"	24"	30"
2	2.32-2.63	CR1 - 263 - Length	4	5	6	7	10	—	—	—
2 1/4	2.57-2.87	CR1 - 287 - Length	4	5	6	7	10	—	—	—
2 1/4-2 1/2	2.70-3.00	CR1 - 300 - Length	4	5	6	7	10	—	—	—
3	2.95-3.25	CR1 - 325 - Length	4	5	6	8	10	—	—	—
	3.40-3.70	CR1 - 370 - Length	4	6	7	9	12	—	—	—
3 & 4	3.71-4.00	CR1 - 400 - Length	—	6	7	9	12	—	—	—
4	4.45-4.75	CR1 - 475 - Length	—	7	8	10	13	17	—	—
	4.75-5.15	CR1 - 515 - Length	—	7	8	10	13	17	20	25
4 & 5	4.95-5.35	CR1 - 535 - Length	—	7	8	11	14	18	20	25
	5.20-5.60	CR1 - 560 - Length	—	7	8	11	14	18	20	26
6	5.95-6.35	CR1 - 635 - Length	—	8	10	11	15	19	22	30
	6.55-6.95	CR1 - 695 - Length	—	8	10	11	15	19	23	30
	6.84-7.24	CR1 - 724 - Length	—	9	11	12	16	20	24	32
	7.05-7.45	CR1 - 745 - Length	—	9	11	12	17	21	25	32
8	7.45-7.85	CR1 - 785 - Length	—	9	11	13	18	22	26	34
	7.95-8.35	CR1 - 835 - Length	—	9	12	14	19	23	28	35
	8.59-8.99	CR1 - 899 - Length	—	9	12	14	19	23	28	35
	9.00-9.40	CR1 - 940 - Length	—	10	13	14	20	24	29	37
8 & 10	9.30-9.70	CR1 - 970 - Length	—	10	13	15	20	25	31	38
	9.75-10.15	CR1 - 1015 - Length	—	11	13	16	21	27	32	40
10	10.65-11.05	CR1 - 1105 - Length	—	11	14	17	22	28	34	42
	11.04-11.44	CR1 - 1144 - Length	—	12	14	17	22	29	36	44
	11.35-11.75	CR1 - 1175 - Length	—	12	14	17	23	30	37	45
	11.75-12.15	CR1 - 1215 - Length	—	13	15	18	24	30	37	46
	11.95-12.35	CR1 - 1235 - Length	—	13	15	18	26	31	38	47
12	12.65-13.05	CR1 - 1305 - Length	—	14	16	19	28	32	38	48
	13.10-13.50	CR1 - 1350 - Length	—	15	17	20	28	32	38	48
	13.40-13.80	CR1 - 1380 - Length	—	15	18	21	29	33	39	48
12 & 14	13.70-14.10	CR1 - 1410 - Length	—	16	18	21	29	33	39	48
	14.00-14.40	CR1 - 1440 - Length	—	16	19	22	29	35	41	52
Number of Studs			2	2	3	3	4	5	6	8

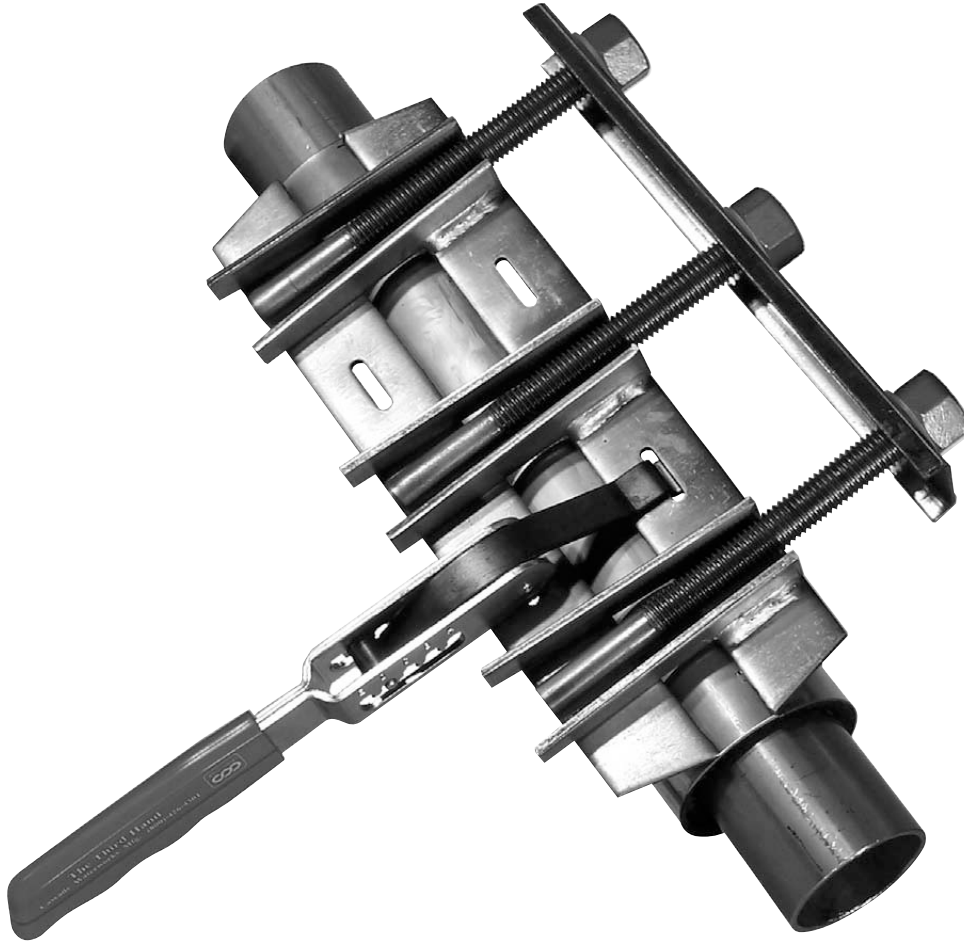

FEATURES & BENEFITS

- Easier to attach Repair Clamps to pipe (especially smaller Pipe ODs)
- Safely attach Repair Clamps to Pipe — Clamp is held in place while the nuts are tightened
- Easier to slide Repair Clamp into place over leak
- Adjustability for all:
 - CR Series Repair Clamps & (CR1, CR2, CR2-SR, CR3)
 - CRT Series Tapped Repair Clamps (CRT1, CRT2, CRT2-SR, CRT3)
- Compact tool size
- Materials resistant to wear
- Saves time during installation
- More consistent installations
- Able to handle harsh environments
- Designed for Left-handed or Right-handed use
- Easy to use
- Lifetime warranty
- Patent Pending

Catalog Number: CR1-TOOL

STYLE CR2/CR2-SR

TWO SECTION DOUBLE/SUPER RANGE



To Order: Determine desired range and length, then select corresponding catalog number.

Note: Other ranges and lengths not listed are available upon request. For higher pressures, clamp length should be equal to or in excess of pipe O.D.

Conductivity Strips available upon request.

Nominal Pipe Size (Inches)	Clamp O.D. Range (Inches)	Catalog Number	Approximate Shipping Weight (lbs.) per length						
			8"	10"	12"	16"	20"	24"	30"
4	4.44-5.26	CR2 - 526 - Length	12	14	17	24	28	34	42
	4.75-5.57	CR2 - 557 - Length	13	15	18	26	30	39	45
6	6.56-7.36	CR2 - 736 - Length	14	18	21	28	34	44	53
	6.84-7.64	CR2 - 764 - Length	15	19	23	29	36	46	56
8	8.60-9.40	CR2 - 940 - Length	17	21	25	30	38	48	59
	8.99-9.79	CR2 - 979 - Length	17	21	25	31	38	48	59
10	10.70-11.50	CR2 - 1150 - Length	22	25	27	33	40	49	60
	11.05-11.85	CR2 - 1185 - Length	22	25	27	33	40	49	60
	11.40-12.20	CR2 - 1220 - Length	23	26	28	35	41	50	61
12	12.70-13.50	CR2 - 1350 - Length	24	26	29	36	42	51	63
	13.15-13.95	CR2 - 1395 - Length	25	27	30	37	43	52	63
	13.60-14.40	CR2 - 1440 - Length	25	27	31	39	44	53	64
	13.85-14.65	CR2 - 1465 - Length	25	27	32	40	45	55	66
14	14.38-15.18	CR2 - 1518 - Length	26	28	33	41	46	57	69
	15.07-15.87	CR2 - 1587 - Length	27	29	34	42	47	58	71
16	15.92-16.67	CR2 - 1667 - Length	28	31	35	43	50	64	74
	16.56-17.31	CR2 - 1731 - Length	30	32	36	44	51	64	77
	17.15-17.90	CR2 - 1790 - Length	31	34	36	44	55	71	84
18	17.82-18.57	CR2 - 1857 - Length	32	35	38	46	56	73	86
	18.46-19.21	CR2 - 1921 - Length	33	36	39	47	58	74	87
	19.23-19.98	CR2 - 1998 - Length	34	38	40	48	60	76	89
20	19.90-20.65	CR2 - 2065 - Length	35	38	41	49	61	80	93
	20.70-21.45	CR2 - 2145 - Length	36	39	43	51	63	83	101
	21.52-22.27	CR2 - 2227 - Length	37	40	45	53	67	88	101
	22.12-22.87	CR2 - 2287 - Length	38	41	47	55	70	92	105
	22.90-23.65	CR2 - 2365 - Length	39	43	49	58	75	98	111
Number of Studs			4	6	6	8	10	12	16

CR2-SR MATERIAL SPECIFICATIONS

Fasteners: T304 SS 5/8x11 NC Rolled Thread, Heavy Hex Nuts.

Shell/Lugs/Bars: T-304 SS.

Bearing Washers/Washer Plates: T-304 SS.

Gaskets: Virgin SBR (Other compounds available upon request)

Lubricating Washers: Nylon.

8	8.60-9.80	CR2 - SR - 980 - Length	18	22	27	34	42	52	64
	10.70-11.90	CR2 - SR - 1190 - Length	23	27	31	40	46	58	72
10	11.05-12.25	CR2 - SR - 1225 - Length	23	27	31	40	46	58	72
	12.70-13.90	CR2 - SR - 1390 - Length	23	27	31	40	46	58	72
12-14	13.15-14.35	CR2 - SR - 1435 - Length	26	29	36	45	57	74	84
	13.65-14.85	CR2 - SR - 1485 - Length	26	29	36	45	57	74	84
14-16	14.45-15.65	CR2 - SR - 1565 - Length	26	29	36	45	57	74	84
	14.85-16.05	CR2 - SR - 1605 - Length	28	32	39	48	61	81	94
	15.92-17.12	CR2 - SR - 1712 - Length	28	32	35	48	61	81	94
16-18	17.15-18.35	CR2 - SR - 1835 - Length	33	37	43	52	65	85	101
	18.46-19.66	CR2 - SR - 1966 - Length	33	37	43	52	65	85	101
18-20	19.45-20.65	CR2 - SR - 2065 - Length	39	42	48	57	73	95	107
	21.50-22.70	CR2 - SR - 2270 - Length	39	42	48	57	73	95	107

STYLE CR3

THREE SECTION EXTENDED RANGE



To Order: Determine desired range and length, then select corresponding catalog number.

Note: Other ranges and lengths not listed are available upon request. For higher pressures, clamp length should be equal to or in excess of pipe O.D.

Conductivity Strips available upon request.

Clamp O.D. Range (Inches)	Catalog Number	Approximate Shipping Weight (lbs.) per length					
		10"	12"	16"	20"	24"	30"
11.04-12.24	CR3 - 1224 - Length	26	31	41	53	61	82
13.14-14.34	CR3 - 1434 - Length	28	33	43	54	65	84
13.65-14.85	CR3 - 1485 - Length	29	34	44	55	66	86
14.85-16.05	CR3 - 1605 - Length	30	35	45	56	67	88
15.92-17.12	CR3 - 1712 - Length	32	37	47	58	70	94
17.15-18.35	CR3 - 1835 - Length	33	38	48	59	72	96
18.46-19.66	CR3 - 1966 - Length	34	39	49	62	75	98
19.45-20.65	CR3 - 2065 - Length	36	40	53	67	80	102
21.52-22.72	CR3 - 2272 - Length	—	42	63	72	84	107
23.28-24.48	CR3 - 2448 - Length	—	43	64	77	87	117
24.38-25.58	CR3 - 2558 - Length	—	45	65	78	92	120
25.70-26.90	CR3 - 2690 - Length	—	47	66	80	95	123
26.48-27.68	CR3 - 2768 - Length	—	48	66	82	97	127
27.65-28.85	CR3 - 2885 - Length	—	50	67	85	102	130
28.73-29.93	CR3 - 2993 - Length	—	52	69	88	106	136
29.62-30.82	CR3 - 3082 - Length	—	51	70	78	108	138
31.22-32.42	CR3 - 3242 - Length	—	54	71	90	110	140
Number of Studs		9	9	12	15	18	24

STYLE CRT & CDRT

TAPPED REPAIR CLAMPS

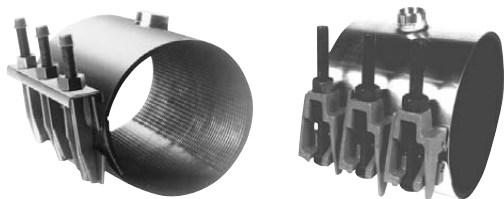

All CR1, CR2, CR2-SR, CR3, and CDR1, CDR2, and CDR3 repair clamps are available with tapped outlets. Outlets are T304 stainless steel permanently bonded to the clamp by Heliarc welding and fully passivated.

To Order: Select size, length and style of clamp. Select type and size of thread for outlet. Add list price for outlet to list price for clamp. Insert the letter "T" into the catalog number and indicate tap size and type style at the end. Consult catalog or factory for specification or application information.

Example: A single band clamp for 6" D.I.P. - 12" long with a 3/4" CC Outlet = CRT1-724-12-3/4CC

Tap Size Available	Type of Threads Available
3/4"	IP or CC
1"	IP or CC
1 1/4"	IP or CC
1 1/2"	IP or CC
2"	IP or CC
2 1/2"	IP only
3"	IP only



Note: Other ranges and widths not listed may be available upon request. For higher pressures, clamp width should be equal or exceed pipe O.D. Conductivity strips are available.

Nominal Pipe Size (Inches)	Clamp O.D. Range (Inches)	Catalog Number	Approximate Shipping Weight (lbs.) per length										
			5"	7.5"	10"	12.5"	15"	20"	25"	30"			
2	2.32-2.63	CDR1 - 263 - Length	7	9	13	16	19	<i>Consult Factory for Weights</i>					
2 1/4	2.57-2.87	CDR1 - 287 - Length	7	9	13	16	19						
2 1/4-2 1/2	2.70-3.00	CDR1 - 300 - Length	7	9	13	16	19						
3	2.95-3.25	CDR1 - 325 - Length	7	11	14	18	21						
	3.40-3.70	CDR1 - 370 - Length	7	11	14	18	21						
3 & 4	3.71-4.00	CDR1 - 400 - Length	7	11	14	18	21						
4	4.45-4.75	CDR1 - 475 - Length	8	11	14	18	21						
	4.75-5.15	CDR1 - 515 - Length	8	11	14	19	23				30	38	45
4 & 5	4.95-5.35	CDR1 - 535 - Length	8	11	15	19	23				30	38	45
	5.20-5.60	CDR1 - 560 - Length	8	11	16	19	23				31	39	46
6	5.95-6.35	CDR1 - 635 - Length	9	12	16	20	23	31	39	46			
	6.55-6.95	CDR1 - 695 - Length	9	12	17	20	24	33	40	47			
	6.84-7.24	CDR1 - 724 - Length	9	12	17	20	24	33	40	47			
	7.05-7.45	CDR1 - 745 - Length	9	12	17	21	25	33	41	49			
8	7.45-7.85	CDR1 - 785 - Length	10	12	17	21	25	34	41	49			
	7.95-8.35	CDR1 - 835 - Length	10	12	17	21	25	34	42	51			
	8.59-8.99	CDR1 - 899 - Length	11	13	18	22	26	35	44	52			
8 & 10	9.00-9.40	CDR1 - 940 - Length	11	13	18	22	26	36	45	52			
	9.30-9.70	CDR1 - 970 - Length	11	13	18	22	26	36	45	54			
10	9.75-10.15	CDR1 - 1015 - Length	11	13	18	23	27	36	45	54			
	10.65-11.05	CDR1 - 1105 - Length	12	14	20	24	29	38	47	56			
	11.04-11.44	CDR1 - 1144 - Length	12	14	20	24	30	39	48	58			
	11.35-11.75	CDR1 - 1175 - Length	12	15	20	25	30	40	49	61			
	11.75-12.15	CDR1 - 1215 - Length	12	15	21	26	30	40	49	61			
12	11.95-12.35	CDR1 - 1235 - Length	12	15	21	26	31	41	50	62			
	12.65-13.05	CDR1 - 1305 - Length	13	16	21	27	31	41	52	63			
	13.10-13.50	CDR1 - 1350 - Length	14	17	22	27	31	42	52	64			
12 & 14	13.40-13.80	CDR1 - 1380 - Length	14	18	22	28	34	44	55	68			
	13.70-14.10	CDR1 - 1410 - Length	15	18	23	29	34	46	59	69			
	14.00-14.40	CDR1 - 1440 - Length	16	19	24	30	36	47	61	71			
Number of Bolts			2	3	4	5	6	8	10	12			

STYLE CDR2

DOUBLE SECTION - WIDER RANGE

Nominal Pipe Size (Inches)	Clamp O.D. Range (Inches)	Catalog Number	Approximate Shipping Weight (lbs.) per length					
			7.5"	10"	12.5"	15"	20"	30"
4	4.44-5.26	CDR2 - 526 - Length	19	26	32	41	52	78
	4.75-5.57	CDR2 - 557 - Length	19	26	32	41	52	78
6	6.58-7.36	CDR2 - 736 - Length	21	28	35	44	53	81
	6.84-7.64	CDR2 - 764 - Length	21	28	35	45	55	83
8	8.99-9.79	CDR2 - 979 - Length	22	30	37	48	59	89
10	10.70-11.50	CDR2 - 1150 - Length	24	31	39	49	60	90
	11.06-11.65	CDR2 - 1165 - Length	25	31	40	50	63	94
	11.40-12.20	CDR2 - 1220 - Length	28	32	41	51	64	96
12	12.70-13.50	CDR2 - 1350 - Length	29	33	43	52	66	97
	13.15-13.95	CDR2 - 1395 - Length	29	33	46	53	66	99
	13.60-14.40	CDR2 - 1440 - Length	30	35	47	53	67	101
	13.85-14.65	CDR2 - 1465 - Length	32	36	49	54	71	102
14	14.38-15.18	CDR2 - 1518 - Length	33	36	-	58	73	111
	15.07-15.87	CDR2 - 1587 - Length	-	38	-	59	75	113
16	15.92-16.67	CDR2 - 1667 - Length	-	38	-	60	75	114
	16.56-17.31	CDR2 - 1731 - Length	-	39	-	62	76	116
	17.15-17.90	CDR2 - 1790 - Length	-	40	-	63	78	118
	17.82-18.62	CDR2 - 1862 - Length	-	40	-	64	78	119
18	18.41-19.21	CDR2 - 1921 - Length	-	41	-	65	79	120
	19.23-19.98	CDR2 - 1998 - Length	-	41	-	65	80	122
	19.90-20.70	CDR2 - 2070 - Length	-	41	-	66	81	124
20	20.70-21.45	CDR2 - 2145 - Length	-	43	-	68	83	125
	21.52-22.27	CDR2 - 2227 - Length	-	45	-	69	86	130
	22.12-22.87	CDR2 - 2287 - Length	-	46	-	69	88	134
	22.90-23.65	CDR2 - 2365 - Length	-	48	-	69	92	139
Number of Bolts			6	8	10	12	16	24

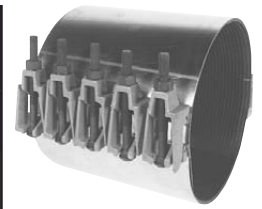

STYLE CDR3

TRIPLE SECTION - EXTENDED RANGE

Clamp O.D. Range (Inches)	Catalog Number	Approximate Shipping Weight (lbs.) per length					
		10"	12.5"	15"	20"	25"	30"
11.04-12.24	CDR3 - 1224 - Length	47	56	72	96	120	152
13.14-14.34	CDR3 - 1434 - Length	50	63	76	100	128	157
13.65-14.85	CDR3 - 1485 - Length	54	67	81	106	134	160
14.85-16.05	CDR3 - 1605 - Length	57	70	85	108	136	162
15.92-17.12	CDR3 - 1712 - Length	60	79	90	112	139	165
17.15-18.35	CDR3 - 1835 - Length	62	81	92	116	143	167
18.46-19.66	CDR3 - 1966 - Length	66	83	96	119	146	170
19.45-20.85	CDR3 - 2085 - Length	69	89	101	123	150	172
21.52-22.72	CDR3 - 2272 - Length	71	90	104	126	153	175
23.28-24.48	CDR3 - 2448 - Length	73	92	108	128	156	180
24.38-25.58	CDR3 - 2558 - Length	-	93	109	131	158	184
25.70-26.90	CDR3 - 2690 - Length	-	95	110	133	161	189
26.48-27.68	CDR3 - 2768 - Length	-	97	113	164	164	190
27.65-28.85	CDR3 - 2885 - Length	-	99	115	140	166	196
28.73-29.93	CDR3 - 2993 - Length	-	100	117	144	170	198
29.62-30.82	CDR3 - 3082 - Length	-	102	120	147	175	200
31.22-32.42	CDR3 - 3242 - Length	-	113	139	160	188	202
Number of Bolts		9	12	15	18	24	36



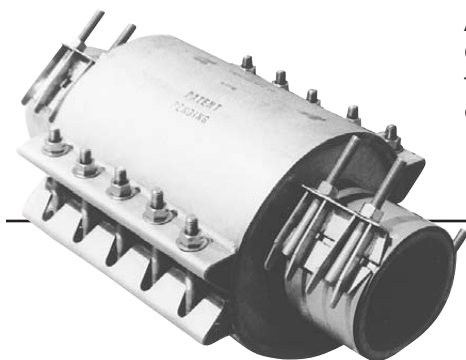

A Cascade Invention Patent No. 5,288,108.

Quick and complete repair of cracked bell without cutting pipe and shutting down line. Pipes can be repaired under pressure, eliminating costly chlorination and notification of boil water notices.

MATERIAL SPECIFICATIONS

- Fully encloses any type of Bell Joint or coupling
- All Stainless Steel, the ultimate corrosion protection
- Custom designed to fit any size diameter
- Material specification: lugs, retaining rings, fasteners, housing T-304 SST
- Gasket - Virgin SBR
- Other compounds available

To Order: Determine actual pipe O.D., Bell type, and bell O.D., then select the corresponding catalog number.

Note: Due to any variety of Bells in service, please obtain precise dimensions.

Consult Cascade if crack is longer than 8 in.

Nominal Pipe Size (Inches)	Catalog Number	Approx. Shipping Wt.	
		Bell & Spigot	Mechanical Joint
4	CRBJ - 480 CRBJ - 510	125	135
6	CRBJ - 690 CRBJ - 710	180	190
8	CRBJ - 905 CRBJ - 940	225	235
10	CRBJ - 1110 CRBJ - 1140	290	300
12	CRBJ - 1320 CRBJ - 1350	355	365
14	CRBJ - 1530 CRBJ - 1565	410	420
16	CRBJ - 1740 CRBJ - 1780	475	485

Nominal Pipe Size (Inches)	Catalog Number	Approx. Shipping Wt.	
		Bell & Spigot	Mechanical Joint
18	CRBJ - 1950 CRBJ - 1992	535	545
20	CRBJ - 2160 CRBJ - 2206	600	619
24	CRBJ - 2580 CRBJ - 2632	695	705
30	CRBJ - 3174 CRBJ - 3200	810	820
36	CRBJ - 3830	910	940
42	CRBJ - 4450	1080	1120
48	CRBJ - 5080	1200	1240

Other sizes available upon request.



For easy repair of leaking solvent welded PVC pipe joints.

To Order: Determine desired range and length, then select corresponding catalog number.

Nominal Pipe Size (Inches)	Clamp O.D. Range (Inches)	Catalog Number	Approximate Shipping Weight (lbs.) per length			
			6"	8"	12"	16"
2	2.375	CCLC - 238 - Length	5	6	7	9
2 1/2	2.875	CCLC - 288 - Length	5	6	7	9
3	3.50	CCLC - 350 - Length	5	6	7	9
4	4.50	CCLC - 450 - Length	6	7	8	10
6	6.63	CCLC - 663 - Length	7	8	9	11
8	8.63	CCLC - 863 - Length	8	9	10	12

NOTE: Other sizes available upon request. Standard CCLC designed for Class 160 and SDR 26 PVC solvent weld collars.

WARRANTY

Cascade Waterworks Mfg. Co. warrants its product(s) for one year from the date of shipment to be free of defects in material or workmanship. Cascade will repair or replace this product if it is found to be defective within the above stated one year warranty period provided that the buyer submits his claim in writing and delivers the original claimed defective product in its entirety, freight prepaid to Cascade Waterworks Mfg. Co., 1213 Badger Street, Yorkville, IL, 60560 for inspection within 30 days. Written notice or products sent to Mfg. Reps or any other agents will not be honored as valid warranty claims. Cascade is not liable or responsible for any loss, damage or injury to any person(s) or property

directly or indirectly arising from the use or inability to use this product. The user shall determine the suitability of the product for its intended use prior to any application and said user assumes all risks in connection with the use of this product. No claims for labor or damage will be allowed. Buyer must advise Cascade within 30 days of discovery of the alleged defect or the claim will be barred. This warranty is exclusive and in lieu of all others, whether written, oral or implied. Upon the product(s) purchase from Cascade Waterworks Mfg. Co., or any of its Agents, the purchaser agrees to all of the above terms of warranty.

04/07

PIPE OUTSIDE DIAMETER GUIDE

Outside diameter of pipe may change from time to time. The information contained in this chart is the best available from various manufacturers at the time of printing. An O.D. tape should be used to confirm these diameters prior to ordering fittings.

Nominal Pipe Size (Inches)	1/2	3/4	1	1 1/4	1 1/2	2	2 1/2	3	4	5	6	8	10	12	14	15	16	18	20	24	30
CAST IRON PIPE																					
Class 100-250 AWWA Centrifugal								3.96	4.80		6.90	9.05	11.10	13.20	15.30		17.40	19.50	21.60	25.80	32.00
Class A AWWA Pit Cast						2.50		3.80	4.80		6.90	9.05	11.10	13.20	15.30		17.40	19.50	21.60	25.80	31.74
Class B AWWA Pit Cast								3.96	5.00		7.10	9.05	11.10	13.20	15.30		17.40	19.50	21.60	25.80	32.00
Class C-D AWWA Pit Cast								3.96	5.00		7.10	9.30	11.40	13.50	15.65		17.80	19.92	22.06	26.32	
MISC. PIPING																					
Copper Tubing	.63	.88	1.13	1.38	1.63	2.13	2.63	3.13	4.13	5.13	6.13										
Steel Pipe - Schedule 40	.84	1.05	1.32	1.66	1.90	2.38	2.88	3.50	4.50	5.56	6.63	8.63	10.75	12.75	14.00		16.00	18.00	20.00	24.00	30.00
Plastic Pipe - (PVC) - STD			1.32		1.90	2.38	2.88	3.50	4.50	5.56	6.63	8.63	10.75	12.75							
Plastic Pipe - (PVC) - C.I. Size									4.80		6.90	9.05	11.10	13.20							
Plastic Irrigation Pipe (PIP)									4.13		6.14	8.16	10.20	12.24		15.30					
Plastic Sewer Pipe ASTM D-3034									4.22		6.28	8.40	10.50	12.50		15.30		18.70		24.80	
ASBESTOS - CEMENT PIPE																					
Class 100																					
Machined End								3.74	4.64		6.91	9.11	11.24	13.40	15.07		17.15				
Fluid-Tite Rough Barrel								3.93	5.05		7.16	9.32	11.46	13.70	15.36		17.50				
Flintite Rough Barrel								3.94	4.90		7.13	9.33	11.30	13.42	15.45		17.60				
Ring-Tite Rough Barrel								3.95	4.92		7.19	9.39	11.47	13.74	15.51		17.65				
Permaflex Rough Barrel									4.84		7.15	9.35	11.47	13.74	15.55		17.55				
Minimum Std. Rough Barrel									4.79		7.05	9.22	11.25	13.37	15.36		17.50				
Maximum Std. Rough Barrel									5.26		7.40	9.57	11.77	14.04	15.80		17.94				
Class 150																					
Machined End								3.84	4.81		6.91	9.11	11.66	13.92	16.22		18.46				
Fluid-Tite Rough Barrel								4.03	5.14		7.12	9.32	11.85	14.11	16.41		18.65				
Flintite Rough Barrel								4.04	5.01		7.13	9.33	11.88	14.14	16.48		18.72				
Ring-Tite Rough Barrel								4.13	5.07		7.17	9.37	11.92	14.18	16.48		18.72				
Permaflex Rough Barrel									5.00		7.20	9.40	11.92	14.20	16.50		18.75				
Minimum Std. Rough Barrel									4.97		7.07	9.27	11.82	14.08	16.38		18.62				
Maximum Std. Rough Barrel									5.32		7.37	9.62	12.12	14.38	16.73		18.97				
Class 200																					
Machined End								3.84	4.81		6.91	9.11	11.66	13.92	16.22		18.46				
Fluid-Tite Rough Barrel								4.18	5.32		7.36	9.46	11.88	14.11	16.44		18.74				
Flintite Rough Barrel								4.17	5.32		7.26	9.44	11.88	14.14	16.53		18.84				
Ring-Tite Rough Barrel								4.17	5.33		7.32	9.50	11.92	14.18	16.55		18.90				
Permaflex Rough Barrel									5.32		7.26	9.50	11.95	14.20	16.55		18.90				
Minimum Std. Rough Barrel									5.22		7.26	9.39	11.77	14.03	16.44		18.74				
Maximum Std. Rough Barrel									5.57		7.60	9.79	12.12	14.38	16.88		19.19				
Nominal Pipe Size (Inches)	1/2	3/4	1	1 1/4	1 1/2	2	2 1/2	3	4	5	6	8	10	12	14	15	16	18	20	24	30

*Flintite M.E. is 10.89 for 10" and 12.99 for 12" sizes.

Always measure pipe outside diameter (O.D.) or circumference before ordering fitting.